

RFID Inlay - GB24U9

Applications

Inventory - Logistics - Loss Prevention - Supply Chain Management

Key Benefits

- ✓ Pre-Serialization of 96 bit EPC
- ✓ 3D Orientation Design
- ✓ Designed to Function with EAS

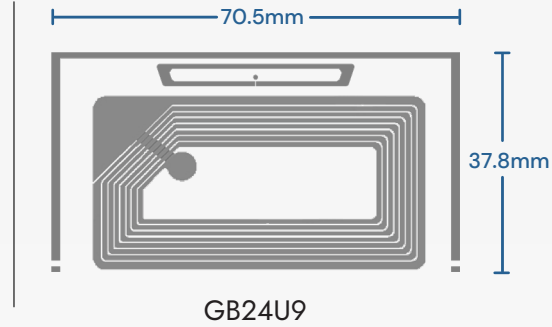

Technical Features

Antenna Size / Web Width	70.5 X 37.8 mm [2.78 X 1.49 in] / 90 mm [3.54 in]
Integrated Circuit (IC) Type	NXP UCODE 9
Operating Frequency	860 - 960MHz
RF Communications Protocol	ISO/IEC 18000-63 and EPC Global Class 1 Gen2
ARC Approved Spec	F, G, I, K, L, N, Q
Chip Memory	96 bits EPC
Inlay Substrate Material	PET
IC Features	Auto Adjust Technology, Brand Identifier, Pre-serialized 96bit EPC, Broad Bandwidth
Read Sensitivity	-24 dBm
Write Sensitivity	-22 dBm
Operating Temperature	-5°C to 60°C / 23°F to 140°F
Operating Humidity	20% - 60% RH

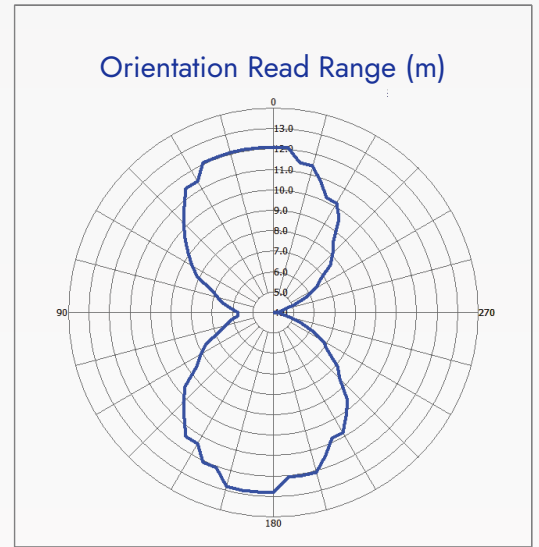

Sensitivity Results from Free Space (dBm)

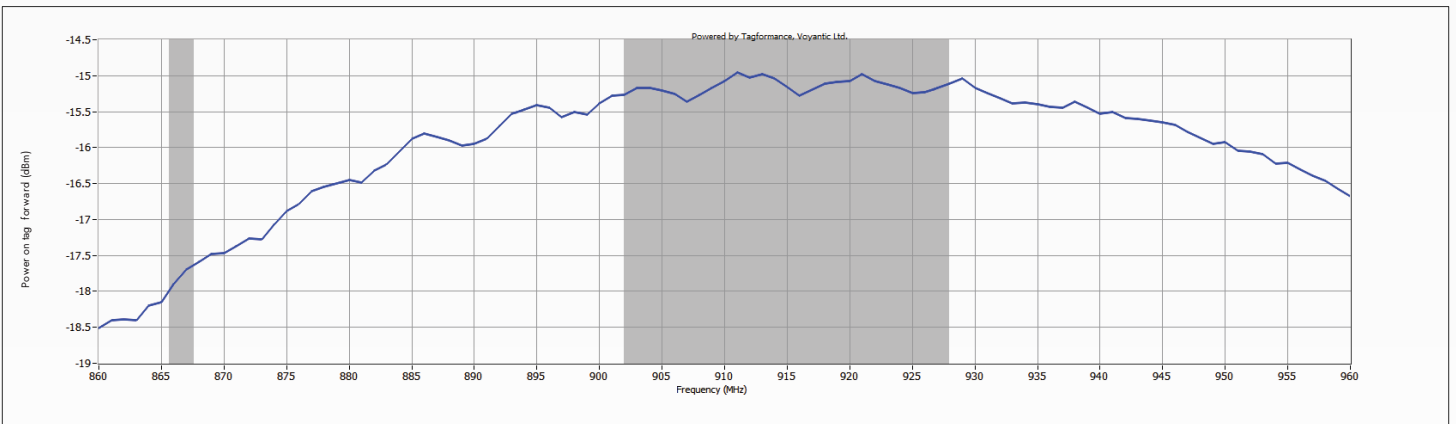

For more information, please contact us at sml.com/requestinfo.



This product should be tested by the customer / user thoroughly to ensure conformity to any particular requirements. We do not represent that this product is fit for any particular purpose or use. We reserve all rights to modify, supplement, substitute or discontinue product offerings at any time without notice. The information contained herein is for pure guidance but contains no representation concerning the accuracy or correctness of the data.